

Thursday 25 May 2023 – Morning

GCSE (9–1) Physics B (Twenty First Century Science)

J259/01 Breadth in physics (Foundation Tier)

Time allowed: 1 hour 45 minutes



You must have:

- a ruler (cm/mm)
- the Equation Sheet for GCSE (9–1) Physics B (inside this document)

You can use:

- a scientific or graphical calculator
- an HB pencil



Please write clearly in black ink. **Do not write in the barcodes.**

Centre number

--	--	--	--	--

Candidate number

--	--	--	--

First name(s)

Last name

INSTRUCTIONS

- Use black ink. You can use an HB pencil, but only for graphs and diagrams.
- Write your answer to each question in the space provided. If you need extra space use the lined pages at the end of this booklet. The question numbers must be clearly shown.
- Answer **all** the questions.
- Where appropriate, your answers should be supported with working. Marks might be given for using a correct method, even if your answer is wrong.

INFORMATION

- The total mark for this paper is **90**.
- The marks for each question are shown in brackets [].
- This document has **32** pages.

ADVICE

- Read each question carefully before you start your answer.

1 The diagram shows a hydroelectric power station.

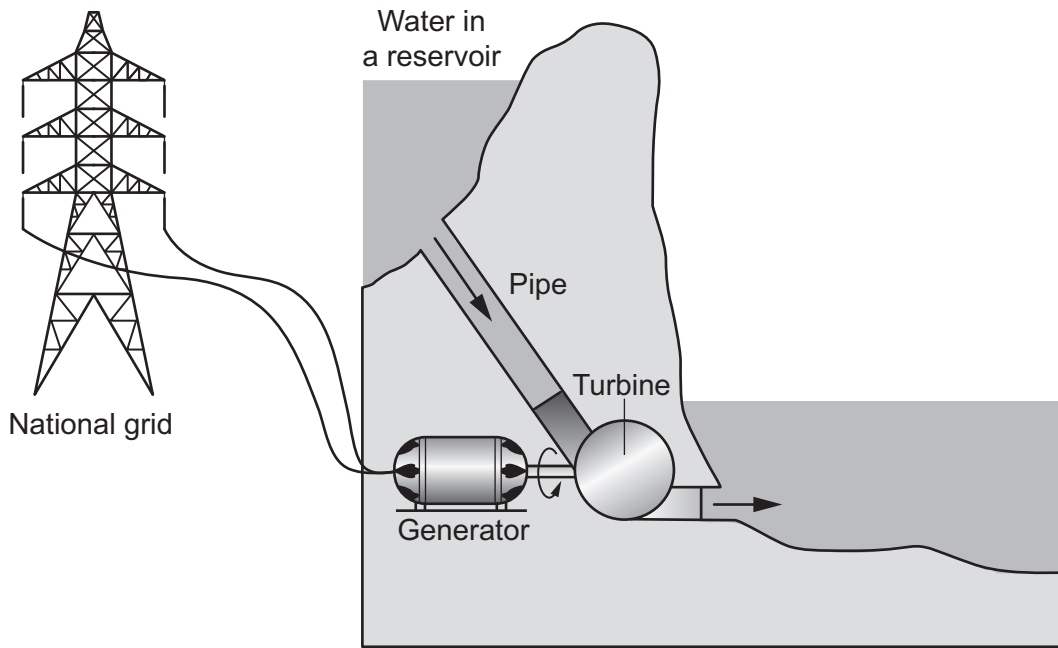

(a) What is the useful energy store of the water in the reservoir?

Tick (✓) **one** box.

Chemical

Electrical

Gravitational Potential

Thermal

[1]

(b) Many of the main energy resources use a turbine attached to a generator.

Complete the table to state what drives the turbine for each energy resource.

Tick (✓) **one** box in each row.

	What drives the turbine		
	Water	Wind	Steam
Energy resource			
Gas power			
Nuclear power			
Tidal power			

[3]

- (c) A Sankey diagram of the energy transferred in the hydroelectric power station during one hour is shown.

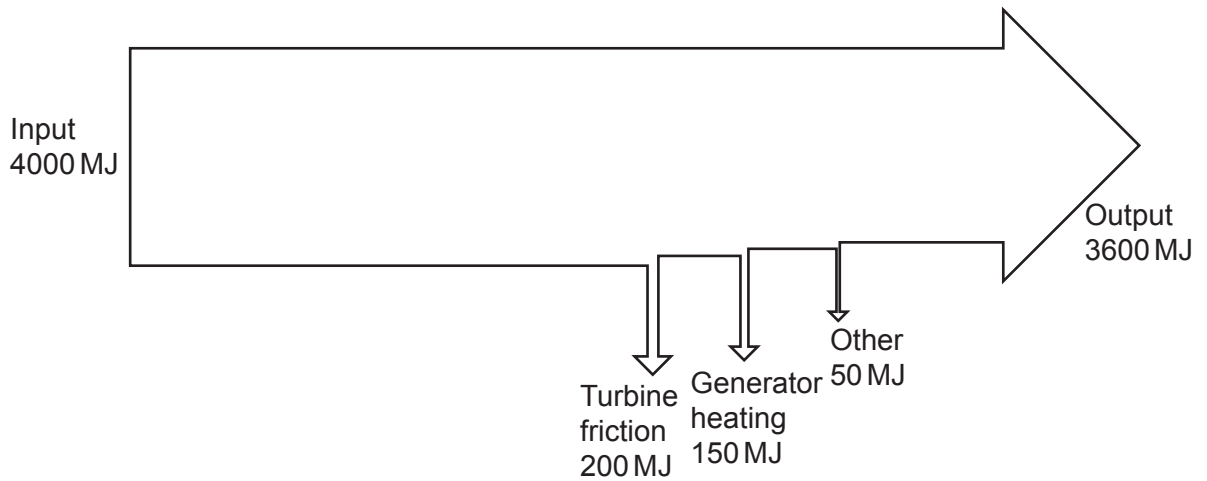

- (i) Calculate the total energy wasted every hour.

Wasted energy = MJ [1]

- (ii) Suggest how to reduce the unwanted energy transfer due to friction as the turbine rotates.

.....
 [1]

- (d) Calculate the power output of the hydroelectric power station.

Use:

- the equation: $\text{power} = \frac{\text{energy transferred}}{\text{time}}$
- the data in the Sankey diagram
- the information: 1 hour = 3600 seconds.

Power output = MW [2]

2 This question is about electromagnetic radiation.

(a) Complete the sentence about the human eye.

Put a **ring** around the correct option.

The human eye can detect a **wide** / **varied** / **narrow** range of frequencies of electromagnetic radiation.



[1]

(b) Complete the description of light. Use words from the list.

charge	detector	energy	source
---------------	-----------------	---------------	---------------

When light is emitted by a, it transfers and the eye absorbs it. [1]

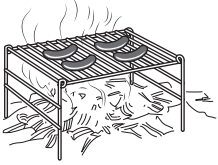
(c) Every object emits electromagnetic radiation with different frequencies. Some examples are given in the table.

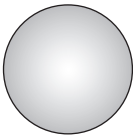
Object	Typical frequency of radiation emitted (THz)
Red hot barbecue 	461
The Earth 	29
The Sun 	600

(i) Put the frequencies in order of **energy**, from lowest to highest.

Lowest energy
 ↓
 Highest energy

[1]

- (ii) What happens to the wavelength emitted from an object as its temperature increases?

Tick (✓) **one** box.

The wavelength decreases.

The wavelength increases.

The wavelength stays the same.

[1]

- (d) Earth emits infrared radiation with a typical wavelength of $10\mu\text{m}$ (10 micrometers).

- (i) State the number of micrometres in 1 metre.

1 m = μm [1]

- (ii) How many times larger is 1 mm than $10\mu\text{m}$?

Tick (✓) **one** box.

10

100

1000

1 000 000

[1]

- 3 A student wants to construct a circuit that turns a lamp on when it gets dark.

A circuit can be a series or a parallel circuit.

- (a) Which statement is correct?

Tick (✓) **one** box.

Current splits at branches in a parallel circuit.

Potential difference across each component in a branch is the same.

Potential difference is shared between all the branches of a parallel circuit.

[1]

- (b) The student builds the circuit in **Fig. 3.1** using a cell, a lamp, a fixed resistor and an LDR.

Fig. 3.1

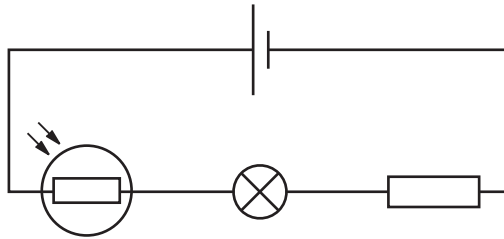

- (i) Which circuit symbol in **Fig. 3.1** represents the fixed resistor?

Put a ring around the correct option in **Fig. 3.1**.

[1]

- (ii) The resistance of the LDR increases in the dark.

What happens to the current in this circuit in the dark?

Tick (✓) **one** box.

The current decreases

The current increases

The current stays the same

[1]

(c) The student builds a second circuit as shown in Fig. 3.2.

Fig. 3.2

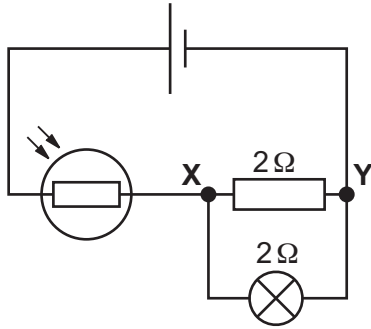

Which **two** statements together explain why the overall resistance between points **X** and **Y** is less than $2\ \Omega$?

Tick (✓) **two** boxes.

More charge can pass than for either component alone.

The lamp only allows current to flow in one direction.

The potential difference across the lamp decreases.

There are two paths for the current to flow.

[2]

(d) Finally, the student builds the circuit shown in **Fig. 3.3**.

The lamp lights up in darkness and does not shine in daylight.

Fig. 3.3

Daylight

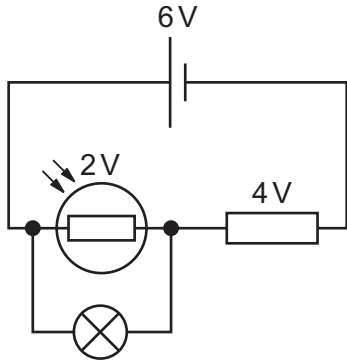

Darkness

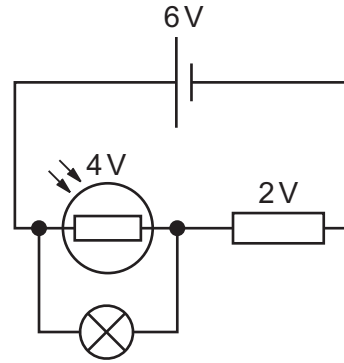

Complete the sentences to explain why the lamp lights in darkness.

Use words from the list.

current	potential difference	power	resistance
----------------	-----------------------------	--------------	-------------------

In darkness, the resistance of the LDR increases, and this means that the
..... across the LDR also increases.

The lamp has the same as the LDR, so the lamp is able to light. [2]

(e) The energy transferred by the lamp is 3.2J when the potential difference is 4.0V.

Calculate the charge flowing through the lamp.

Use the equation: charge = $\frac{\text{energy transferred}}{\text{potential difference}}$

State the **unit**.

Charge = Unit = [3]

BLANK PAGE

PLEASE DO NOT WRITE ON THIS PAGE

4 Light interacts with different materials.

(a) The images show clear plastic and black plastic shirt buttons.



(i) Why do the clear buttons look clear when light is shone at them?

.....
..... [1]

(ii) Why do the black buttons look black when light is shone at them?

.....
..... [1]

(b) Fig. 4.1 shows the path of some rays of light passing through two different types of glass lens.

Fig. 4.1

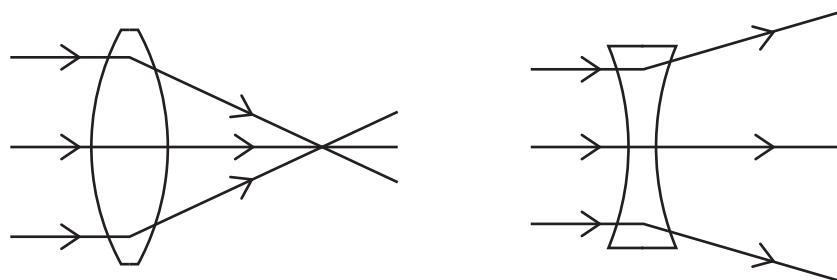

State **one** similarity and **one** difference between these two glass lenses.

Similarity

Difference

[2]

(c) White light is shone at a glass prism, as shown in Fig. 4.2.

Fig. 4.2

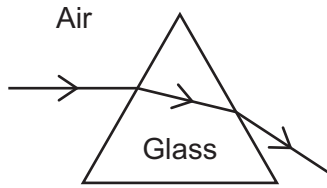

Describe what happens to the light as it travels from the air, through the glass prism and back into the air.

.....

.....

.....

..... [2]

(d) A student investigates the relationship between the angle of incidence and angle of refraction for a ray of light passing through a glass block.

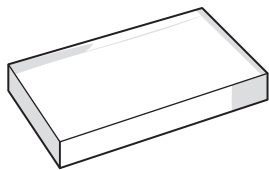

This is the student's method:

- Put a glass block on some paper.
- Shine the light from a raybox into the glass block.
- Mark the path of the rays on the paper with a pen.
- Remove the glass block and the raybox.
- Sketch a line to show the path of the ray inside the glass block.
- Estimate the angle of incidence and angle of refraction.
- Repeat the experiment for one other angle of incidence.

Suggest how the student can improve their method to increase the quality of the data collected.

.....

.....

.....

.....

.....

..... [3]

5 Sound travels through metal and air.

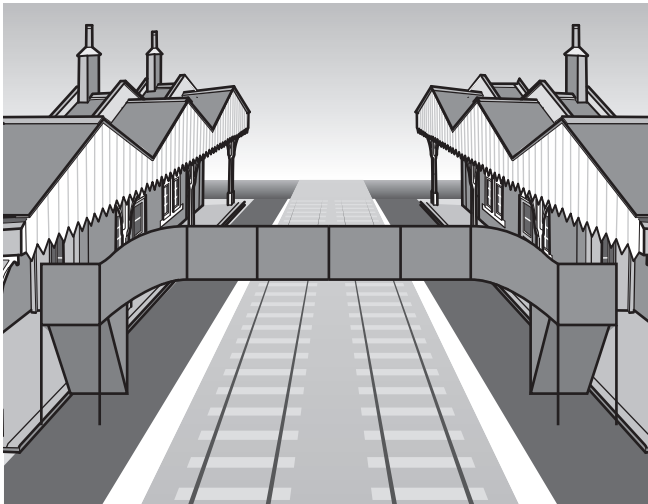

Passengers at a train station notice that they can hear a rumble in the metal rails for nearly a minute before they hear the sound of the train coming.

- (a) The speed of the sound wave in the metal rails is 3300 m/s.

Write down the distance the sound wave travels through the metal rails in 1 second.

Distance = m [1]

- (b) The frequency of the sound wave in the metal rails is 110 Hz.

Calculate the wavelength of the sound wave in the metal rails.

Use the equation: wave speed = frequency \times wavelength

Wavelength = m [3]

- (c) The sound wave in the metal rails causes a sound wave in the air.

The speed of the sound wave in air is 10 times less than the speed of the sound wave in the metal rails. The frequency of the sound wave stays the same.

- (i) Calculate the speed of the sound wave in the air.

Speed = m/s [1]

- (ii) Complete the sentence about the wavelength of the sound wave in the air.

Put a ring around the correct option.

The sound wave in the air has **a longer** / **a shorter** / **the same** wavelength compared to the sound wave in the metal rails.

[1]

- 6 A rugby ball is kicked with an upwards velocity of 20 m/s. The ball has a mass of 0.6 kg.



- (a) (i) Calculate the kinetic energy of the ball just after it has been kicked.

Use the Equation Sheet.

Kinetic energy = J [3]

- (ii) Convert 20 m/s into km/h.

1 km = 1000 m

1 hour = 3600 seconds

20 m/s = km/h [2]

- (b) (i) As the ball moves upwards through the air, some work is done to increase the thermal store of the surroundings.

State the name of the force doing this work.

..... [1]

- (ii) State **one other** energy transfer as the ball moves upwards through the air.

.....
..... [1]

- (iii) Calculate the work done by a force of 3.5 N when the ball moves a distance of 5.2 m through the air in the direction of the force.

Give your answer to **2** significant figures.

Use the equation: work done = force \times distance

Work done = J [3]

- (c) The ball's velocity decreases as it goes upwards. It reaches a maximum height and then its velocity increases as it falls downwards.

State the velocity of the ball at the moment it reaches its maximum height.

Velocity = m/s [1]

- 7 (a) A mountaineer has an empty plastic bottle at the top of a mountain. The lid is off. The arrows on **Fig. 7.1** show the air pressure acting on the inside of the bottle.

Draw **three** arrows on **Fig. 7.1** to show the air pressure acting on the outside of the bottle.

Fig. 7.1

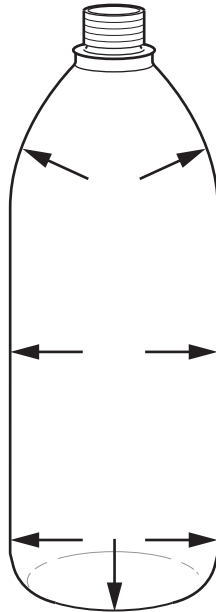

[2]

(b) The mountaineer puts the lid on the bottle and climbs down the mountain.

At the bottom of the mountain, the bottle has a crushed shape, as shown in **Fig. 7.2**.

Fig. 7.2

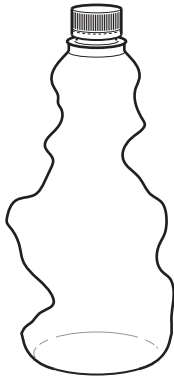

(i) Suggest why the bottle has a crushed shape at the bottom of the mountain.

.....
.....
.....
..... [2]

(ii) Explain why air pressure varies with height above the surface of the Earth.

.....
.....
.....
..... [2]

- (c) A helium balloon is released and rises to the ceiling.



The balloon has a final speed of 2 m/s just before it reaches the ceiling.

Initial speed = 0 m/s

Acceleration = 0.5 m/s²

- (i) Select **one** equation from the Equation Sheet which can be used to find the distance the balloon travels, using the variables given.

.....
 [1]

- (ii) How can you calculate the distance the balloon travels?

Put a **ring** around the correct calculation.

distance = $2^2 - 0^2 - (2 \times 0.5)$ distance = $\frac{(2 \times 0.5)}{(2 - 0)}$

distance = $\frac{2^2 - 0^2}{(2 \times 0.5)}$ distance = $\frac{(2 \times 0.5)}{2^2 - 0^2}$

[1]

- 8 (a) Complete the sentences about radioactive substances.

Put a ring around each correct option.

Atoms in radioactive substances have **balanced** / **stable** / **unstable** nuclei. This means that they will **absorb** / **emit** / **reflect** particles or electromagnetic radiation. [2]

- (b) The nuclear equation shows the radioactive decay of a sulfur nucleus to a chlorine nucleus.

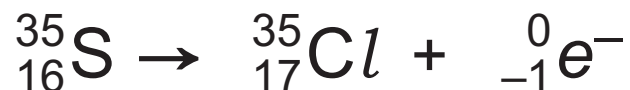

Identify the radioactive decay in the nuclear equation.

Tick (✓) **one** box.

Alpha decay

Beta decay

Gamma decay

[1]

- (c) Which statement explains why sulfur and chlorine are different elements?

Tick (✓) **one** box.

They have different numbers of electrons.

They have different numbers of neutrons.

They have different numbers of protons.

[1]

9 (a) A group of students were asked to suggest questions that science cannot answer.

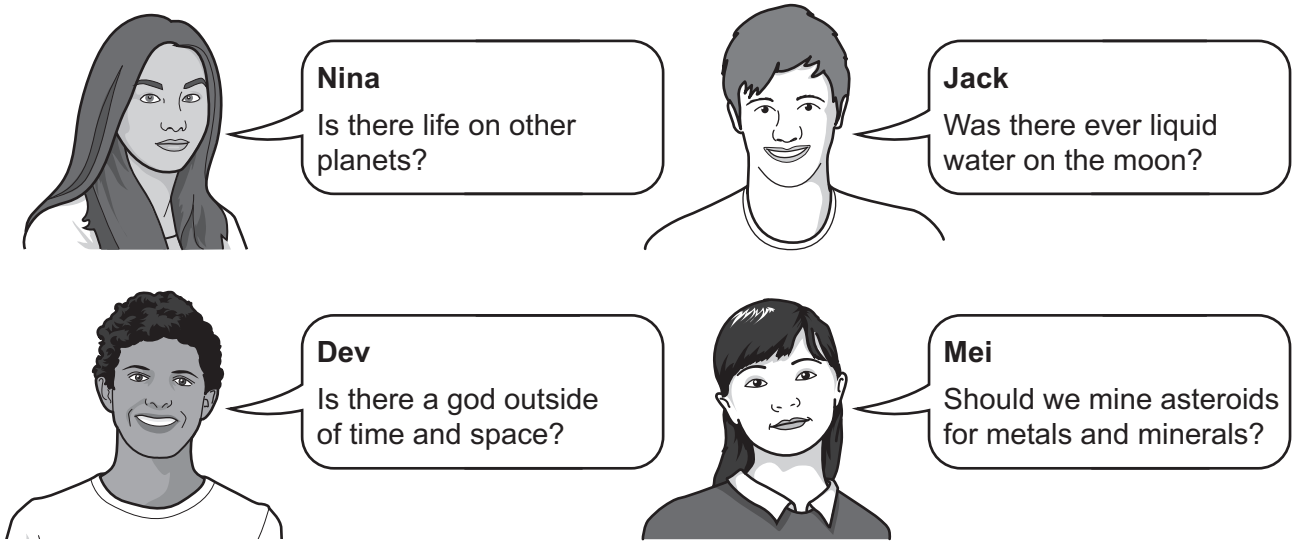

(i) Which **two** students are asking questions that scientific evidence can answer?
..... and [1]

(ii) Which student is asking an ethical question? [1]

(b) Evidence for the Big Bang is a topic that sparks religious and philosophical debate as well as scientific discussion.

One source of evidence for the Big Bang comes from the red shift of light from galaxies.

What causes red shift?

Tick (✓) **one** box.

The temperature of the stars in the galaxy

The direction and speed a galaxy is moving as it emits light

How massive the stars in a galaxy are

[1]

21
BLANK PAGE

PLEASE DO NOT WRITE ON THIS PAGE

(c) The table and the graph show some of the data that first supported the 'Big Bang' theory.

Distance to the galaxy (million light years)	Velocity of the galaxy ($\times 1000$ km/s)
78	1.2
1000	15
1400	22
2500	39
3950	61

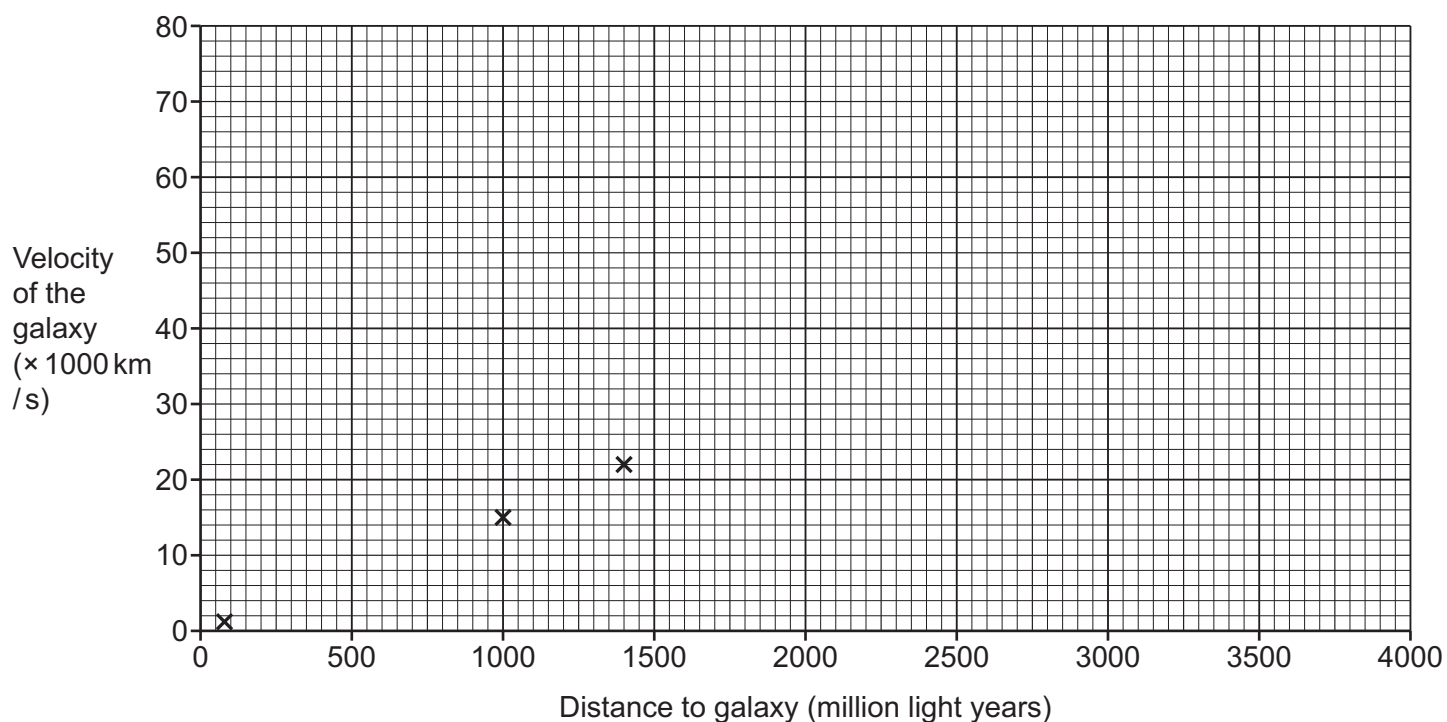

(i) Plot the results from the table on the graph. 3 points have already been plotted.

Include on your graph a line of best fit.

[2]

(ii) What is the relationship between distance and velocity shown by the graph?

Tick (✓) **one** box.

Directly proportional

Inversely proportional

No correlation

Non-linear

[1]

(iii) Identify **two** features of the graph that show this relationship.

1.

2.

[2]

(iv) Describe the 'Big Bang' model.

.....

.....

.....

..... [2]

10 The picture shows a child on a slide. The child's hair is standing on end due to static electricity.



(a) Suggest what has happened to cause the child's hair to stand on end.

.....
.....
.....
..... [2]

(b) Complete the sentence to explain static electricity.

Put a ring around the correct option.

Static electricity is the **sharing** / **storing** / **transfer** of electrons between insulators. [1]

(c) The diagram shows a positively charged balloon, hanging freely from a string.

There is an electric field around the balloon, as shown by the arrows.

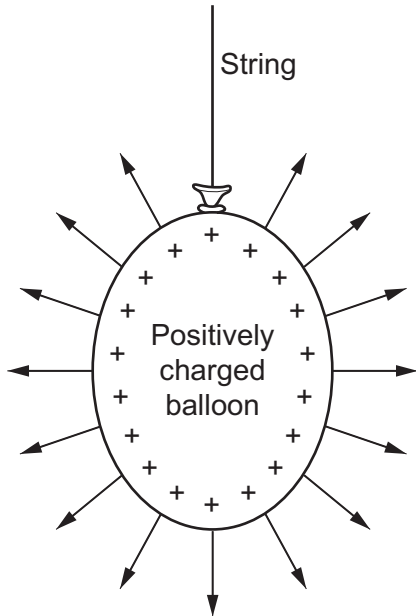

(i) Explain what the direction and spacing of the arrows mean about the electric field.

Direction of arrows

.....

Spacing of arrows

.....

[2]

(ii) A second balloon is brought close to this balloon and the two balloons repel one another.

State the type of charge on the second balloon.

..... [1]

- 11 A student sets up a ripple tank, as shown in the diagram. The dipper dips up and down and sends circular water waves outwards.

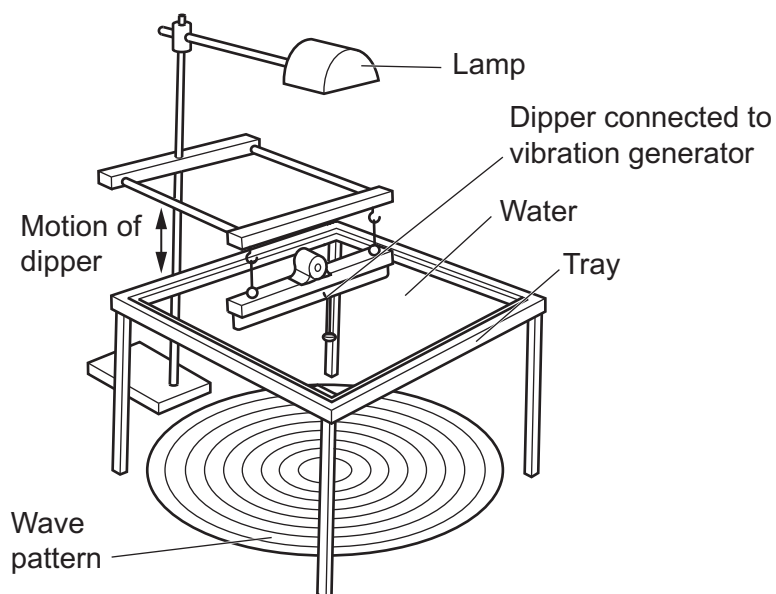

- (a) Which row gives the correct definitions of wavelength and frequency?

Tick (✓) **one** box.

Wavelength	Frequency	
The distance a wave travels in 1 second.	The number of waves in 1 second.	
The distance a wave travels in 1 second.	The time it takes for 1 wave to pass.	
The distance from peak to peak.	The number of waves in 1 second.	
The distance from peak to peak.	The time it takes for 1 wave to pass.	

[1]

- (b) (i) The student takes a photograph of the wave pattern.

State **one** piece of equipment which needs to be included in the photograph to find the wavelength of the water waves.

..... [1]

- (ii) The student then uses a smart phone to record a video of the movement of the water waves for a few seconds.

Describe how the student could use a video to find the frequency of the water waves.

.....
.....
.....
..... [2]

- (iii) How can the student now calculate the speed of the water waves?

.....
..... [1]

12 Fig. 12.1 shows a trolley at the top of a ramp.

Fig. 12.1

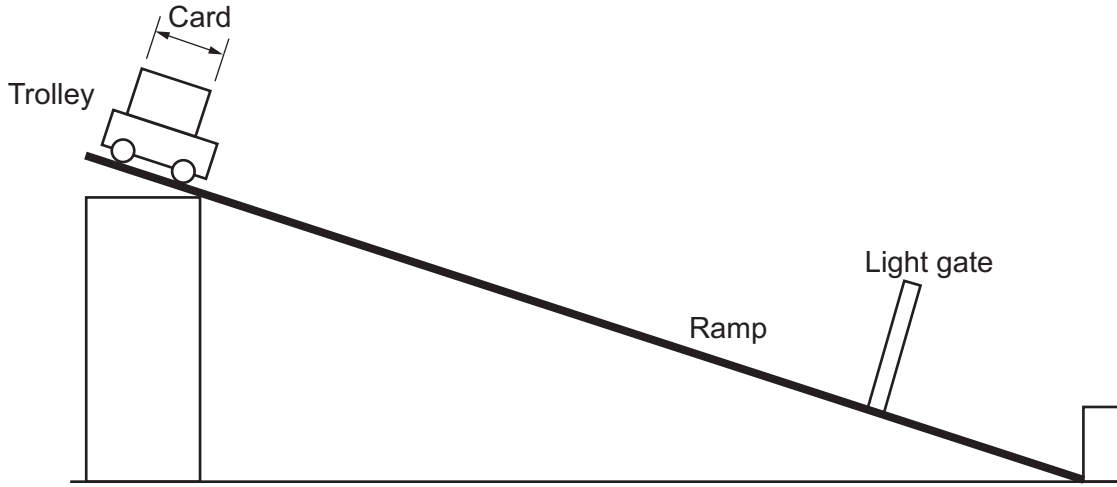

- (a) The trolley is released and accelerates down the ramp. When the trolley passes through the light gate, the instantaneous speed of the trolley is displayed.

Describe how the acceleration of the trolley down the ramp can be calculated using one light gate and a stopclock.

$$\text{Acceleration} = \frac{\text{change in speed}}{\text{time taken}}$$

.....

.....

.....

..... [2]

- (b) A block of wood is placed on the ramp. It exerts a force of 3.2 N on the ramp, perpendicular to the surface of the ramp. This is shown as a vector on **Fig. 12.2**.

Draw **one** vector on **Fig. 12.2** to show the force the ramp exerts on the block of wood, to complete the interaction pair.

Use a ruler.

Fig. 12.2

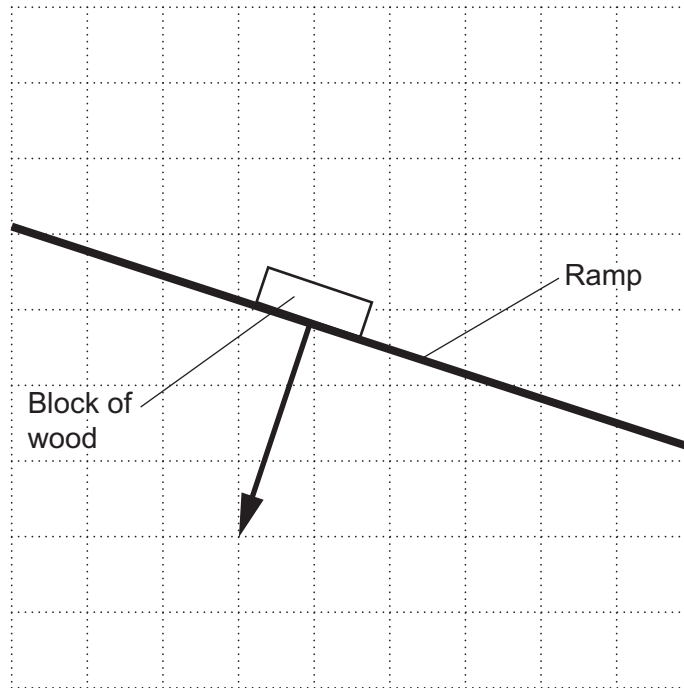

[1]

13 This question is about an inflatable boat.

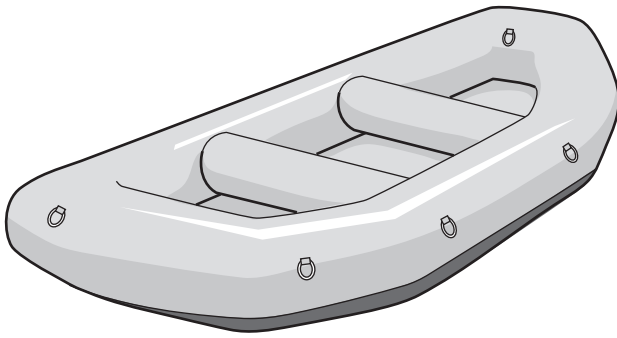

(a) Boats float because they are less dense than water.

Define density.

.....
..... [1]

(b) The boat is inflated in the morning and then left out in the sun. The temperature of the air inside the boat rises to 50 °C.

- The volume and mass of the air inside the inflated boat are constant.
- The table contains data about the average speed of air molecules at different temperatures and pressures.

Temperature (°C)	Average speed of air molecules (m/s)	Pressure (Pa)
20	508	115 000
40	525	122 000
60	542	129 000

Explain why the boat feels firmer after being left out in the Sun.

Use the data in the table. You do not need to do any calculations.

.....
.....
.....
.....
.....
..... [3]

END OF QUESTION PAPER

ADDITIONAL ANSWER SPACE

If additional space is required, you should use the following lined page(s). The question number(s) must be clearly shown in the margin(s).

This block contains a large area of lined paper for writing answers. It features a vertical margin line on the left side and horizontal dotted lines for writing. The lines are evenly spaced and extend across the width of the page.

A large area of the page is reserved for writing, featuring a vertical solid line on the left side and horizontal dotted lines extending across the page.

OCR

Oxford Cambridge and RSA

Copyright Information

OCR is committed to seeking permission to reproduce all third-party content that it uses in its assessment materials. OCR has attempted to identify and contact all copyright holders whose work is used in this paper. To avoid the issue of disclosure of answer-related information to candidates, all copyright acknowledgements are reproduced in the OCR Copyright Acknowledgements Booklet. This is produced for each series of examinations and is freely available to download from our public website (www.ocr.org.uk) after the live examination series.

If OCR has unwittingly failed to correctly acknowledge or clear any third-party content in this assessment material, OCR will be happy to correct its mistake at the earliest possible opportunity.

For queries or further information please contact The OCR Copyright Team, The Triangle Building, Shaftesbury Road, Cambridge CB2 8EA.

OCR is part of Cambridge University Press & Assessment, which is itself a department of the University of Cambridge.